



Modular dock leveller DLH-NG

The newest generation electro hydraulic dock leveller with hinged swing lip.

Features

- Very robust and reliable
- Self-supporting base frame
- Open and self cleaning hinge design
- 2 main cylinders and 1 lip cylinder
- Large variety of models and options
- CE mark and conform to EN 1398

Operation

The DLH-NG dock leveller is operated with only one push button. By keeping the push button pressed, the platform will go up from its rest position, when the highest point is reached, the lip will move out. When the push button is released, the platform and lip will descend automatically to the level of the vehicle bed.

During loading and unloading, each up and down (suspension) movement of the vehicle is automatically followed.

After the loading and unloading process has been completed, by continuously pressing the 'R-button' the dock leveller can be returned to the rest position. In this position, the platform and lip rest onto robust steel lip keepers to prevent the platform from lowering unexpectedly as a result of load stress by cross traffic.

The dock leveller DLH-NG is also suitable to load or unload so-called last cargo below the dock level.

Materials

Platform and lip are made of high-quality durbar plate: durbar plate 6/8 for the platform and durbar plate 12/14 for the lip.

Depending on the width, the platform is reinforced with eight profiles in longitudinal direction. Ramps with a width of 2250 mm are reinforced by ten profiles. These profiles allow the platform top to 'twist' and compensate for vehicle 'tilt' caused by off-set loads within the vehicle. The lip will remain in contact with the vehicle bed.

The rear of the platform is connected to the lower frame by means of three hinges. The pins of the hinges are made of drawn steel rods which can easily withstand the applied forces. Similar pins are used for the lip hinge at the front of the platform top.

The self-supporting characteristics enable either an open or closed pit floor to be selected, or for a so-called letterbox opening to be used. Furthermore the front beam fixed to the lower frame provides protection for the hydraulic and mechanical components on the underside of the dock leveller.

Drive

The platform is powered by two hydraulic cylinders with chrome hardened plunger and double seal. The swinging lip is powered by a separate self-dampening cylinder.

The hydraulic system is completely closed and cannot, even under the most extreme circumstances, be affected by dirt, sand or dust. Thanks to the over sized cylinders, a low working pressure of approximately ± 100 bar is created.

The compact hydraulic power pack is positioned under the platform to prevent it from any possible damages.

All these characteristics ensure a safe hydraulic system with a long life span and a minimum of maintenance.

Building-in possibilities

Because of varying client requirements and constructional elements, a large range of build-in possibilities can be offered. By making the correct choice, considerable cost savings can be made. Detailed build-in drawings are available on request.

Dimensions

The DLH-NG dock leveller can be supplied to customer specifications. For the standard types with a height of 600 mm, a large variety of platform sizes is available.

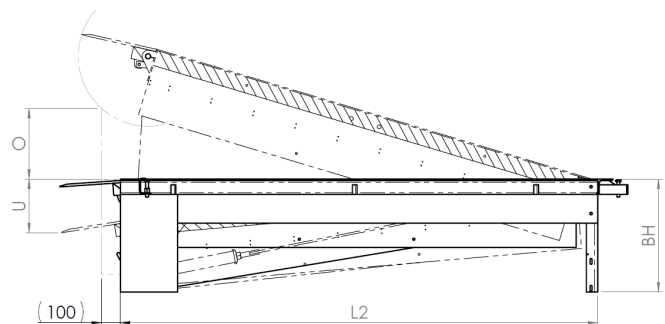

BH = building height O = effective working range above platform
L2 = platform length U = effective working range under platform

L2	BH	O ±	U ±
2000	600	415	290
2500	600	370	280
3000	600	355	275
Platform width: 2000 or 2250 mm		All dimensions in mm	

Standard safety provisions

- Full hydraulic safety stop
- Emergency stop switch with reset facility (panic stop)
- Non retractable sliding toe-guards
- Robust steel lip keepers for transverse movements (cross traffic)
- Black/yellow safety markings
- Non-removable maintenance strut
- Motor safeguard by means of a thermal relay
- Control panel instruction symbols

Technical specifications

Standards.....	CE
Capacity (EN 1398).....	60 kN
Building height.....	600 mm
Lip length.....	400 mm
Lip angle.....	($\pm 4^\circ$) 45 mm
Motor.....	0,75 kW
Power supply.....	400 V / 50 Hz / 2,5 A
Control current.....	24 VDC
Protection class.....	IP 54
Working pressure.....	± 100 bar
Outside diameter main cylinder.....	50 mm
Outside diameter lip cylinder.....	45 mm
Operating temperatures between.....	-30° and +50°
Standard colour.....	RAL 9005 black

Options / accessories

- Various types of pit construction
- Special dimensions
- Higher capacity
- Air seals on three sides of the platforms
- Primer
- Mandurax anti-slip coating on deck and lip
- RAL colour as required
- Polyurea anti-slip and soundproofing coating on deck and lip
- Bottom side of the platform provided with PU insulation
- Other voltage
- Tapered lip on both sides
- Adjustable side segments 1:1 on the lip to adjust to different vehicle widths (only for lip 400 mm)
- Greater lip length
- Hot dip galvanised
- Rest position switch for control of traffic light, door, etc.
- Dock leveller-/door interlocking
- Upgraded protection class